

# Proportional relief valves with integral pressure transducer

digital, two stage, closed loop high performances, rugged design

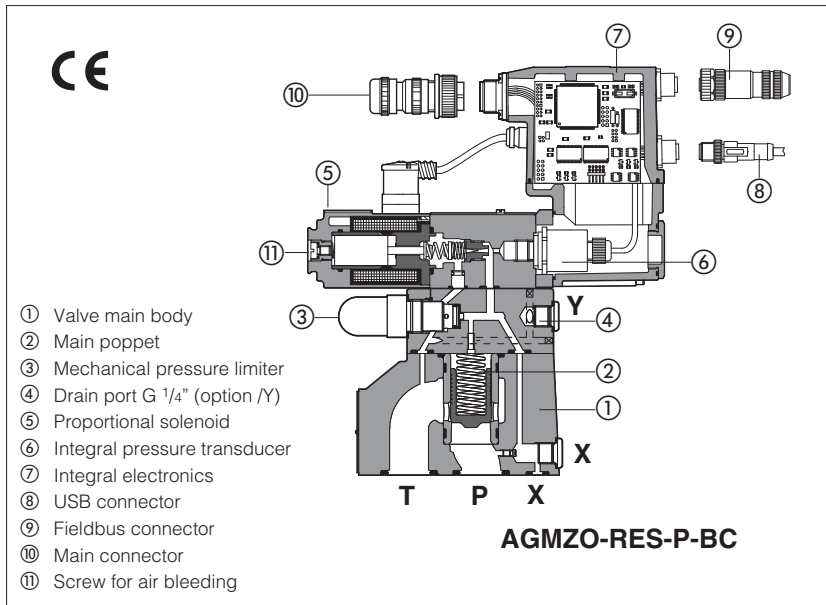

**AGMZO-R, AGMZO-REB, AGMZO-RES**  
Poppet type two stage digital proportional relief valves with integral pressure transducer for pressure closed loop controls.

Executions:

- **R** without integral driver, to be coupled with separated driver type E-BM-RES, see table GS203
- **REB** with basic integral digital electronic driver, analog reference signals and USB port for software functional parameters setting
- **RES** with full integral digital electronic driver and fieldbus interface for functional parameters setting, reference signals and real-time diagnostics

The integral digital electronic driver performs the valve's hydraulic regulation according to the reference signal and assures valve-to-valve interchangeability thanks to the factory presetting

Size: **10, 20, 32**  
Max flow: **200, 400, 600 l/min**  
Max pressure: **350 bar**

## 1 MODEL CODE

<b>AGMZO</b>	-	<b>R</b>	-	<b>EB</b>	-	<b>P</b>	-	<b>NP</b>	-	<b>10</b>	/	<b>315</b>	/	<b>*</b>	/	<b>**</b>	/	<b>*</b>			
Proportional pressure relief valve, two stage		R = closed loop pressure control		EB = basic integral driver		ES = full integral driver		P = with integral pressure transducer		Fieldbus interfaces - USB port always present (1):		NP = Not present		BP = PROFIBUS DP		BC = CANopen		EH = EtherCAT			
Valve size ISO 6264		10, 20, 32		Seals material, see sect. 4, 5:		- = NBR		PE = FKM		BT = HNBR		Series number		Hydraulic options, see section 7:		E = external pilot		Y = external drain (only pipe connection G1/4")			
				Electronics options only for REB and RES - see section 13:		I = current reference input and monitor 4 ÷ 20 mA (omit for standard voltage reference input 0 ÷ 10 V)		Q = enable signal		Z = double power supply, enable fault and monitor signals - 12 pin connector		Max regulated pressure:		100 = 100 bar		315 = 315 bar		210 = 210 bar		350 = 350 bar	

(1) REB available only in version NP; RES available only in version BC, BP, EH

## 2 ELECTRONIC DRIVERS

Valve model	R	REB	RES
Drivers model	E-BM-RES	E-RI-REB	E-RI-RES
Type	Digital		
Format	DIN rail panel format	Integral to valve	
Data sheet	GS203	GS205	

Note: for main and communication connector see sections 15, 16

## Hydraulic symbol

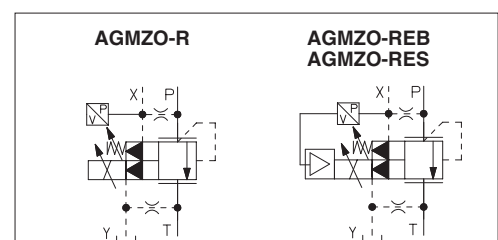

### 3 GENERAL NOTES

AGMZO-R\* proportional valves are CE marked according to the applicable Directives (e.g. Immunity/Emission EMC Directive and Low Voltage Directive). Installation, wirings and start-up procedures must be performed according to the general prescriptions shown in table F003 and in the installation notes supplied with relevant components.

The electrical signals of the valve (e.g. monitor signals) must not be directly used to activate safety functions or components, as prescribed by the European standards (Safety requirements of fluid technology systems and components-hydraulics, EN-982).

### 4 MAIN CHARACTERISTICS - based on mineral oil ISO VG 46 at 50 °C

Assembly position	Any position			
Subplate surface finishing	Roughness index, Ra 0,4 flatness ratio 0,01/100 (ISO 1101)			
MTTFd valves according to EN ISO 13849	75 years, see technical table P007			
Ambient temperature range	standard execution = -20°C ÷ +60°C /BT option = -40°C ÷ +60°C			
Storage temperature range	Standard execution = -20°C ÷ +70°C /BT option = -40°C ÷ +70°C			
Coil resistance R at 20°C	3 ÷ 3,3 Ω			
Max. solenoid current	2,6 A			
Max. power	50 Watt			
Pressure transducer	E-ATR-8*/I output signal = 4÷ 20 mA - see tech. table GS465			
Insulation class	H (180°) Due to the occurring surface temperatures of the solenoid coils, the European standards ISO 13732-1 and EN982 must be taken into account			
Protection degree to DIN EN60529	IP66/67 with mating connectors			
Tropicalization (only REB, RES)	Tropical coating on electronics PCB			
Duty factor	Continuous rating (ED=100%)			
EMC, climate and mechanical load	See technical table G004			
Communication interface (only REB, RES)	USB Atos ASCII coding	CANopen EN50325-4 + DS408	PROFIBUS DP EN50170-2/IEC61158	EtherCAT IEC 61158
Communication physical layer (only REB, RES)	not insulated USB 2.0 + USB OTG	optical insulated CAN ISO11898	optical insulated RS485	Fast Ethernet, insulated 100 Base TX

Valve size	10	20	32
Max regulated pressure [bar]	100; 210; 315; 350		
Min. regulated pressure (Q = 25 l/min) [bar]	7 (10 for /350)	6 (10 for /350)	5,5 (9 for /350)
Max. pressure at port P [bar]	350		
Max. pressure at port T [bar]	210		
Max. flow [l/min]	200	400	600
Response time 0-100% step signal <b>(1)</b> (depending on installation) [ms]	80	100	115
Hysteresis [% of the max pressure]	≤ 0,5		
Linearity [% of the max pressure]	≤ 1,0		
Repeatability [% of the max pressure]	≤ 0,2		
Thermal drift	zero point displacement < 1% at ΔT = 40°C		

**Notes:** above performance data refer to valves coupled with Atos electronic drivers, see section 2.

**(1)** Average value response time; the pressure variation in consequence of a modification of the reference input signal to the valve is affected by the stiffness of the hydraulic circuit: greater is the stiffness of the circuit, faster is the dynamic response, see section 7

### 5 SEALS AND HYDRAULIC FLUID - for other fluids not included in below table, consult our technical office

Seals, recommended fluid temperature	NBR seals (standard) = -20°C ÷ +60°C, with HFC hydraulic fluids = -20°C ÷ +50°C FKM seals (/PE option) = -20°C ÷ +80°C HNBR seals (/BT option) = -40°C ÷ +60°C, with HFC hydraulic fluids = -40°C ÷ +50°C		
Recommended viscosity	20÷100 mm <sup>2</sup> /s - max allowed range 15 ÷ 380 mm <sup>2</sup> /s		
Fluid contamination class	ISO 4406 class 20/18/15 NAS 1638 class 9, achievable with in line filter - 10 μm (β10 ≥75 recommended)		
<b>Hydraulic fluid</b>	<b>Suitable seals type</b>	<b>Classification</b>	<b>Ref. Standard</b>
Mineral oils	NBR, FKM, HNBR	HL, HLP, HLPD, HVLP, HVLPD	DIN 51524
Flame resistant without water	FKM	HFDU, HFDR	ISO 12922
Flame resistant with water	NBR, HNBR	HFC	

**6 DIAGRAMS** (based on mineral oil ISO VG 46 at 50 °C)

**1 = Regulation diagrams**  
with flow rate Q = 50 l/min

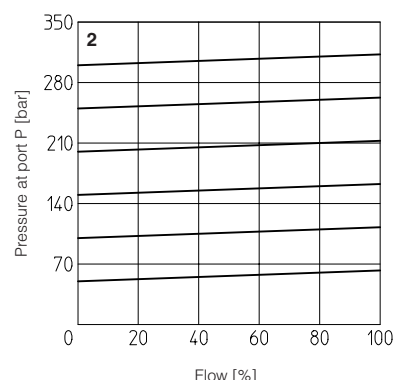
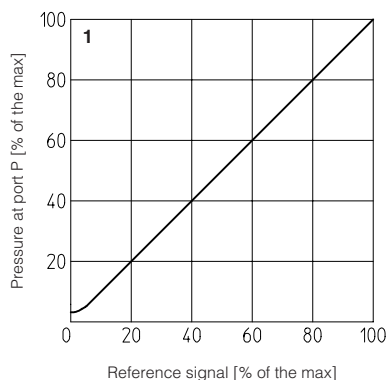

**2 = Pressure/flow diagrams**  
with reference signal set at Q = 50 l/min

**3-8 = Min. pressure/flow diagrams**  
with zero reference signal

- 3 = AGMZO<sup>\*</sup>-10/100, 210, 315
- 4 = AGMZO<sup>\*</sup>-10/350
- 5 = AGMZO<sup>\*</sup>-20/100, 210, 315
- 6 = AGMZO<sup>\*</sup>-20/350
- 7 = AGMZO<sup>\*</sup>-32/100, 210, 315
- 8 = AGMZO<sup>\*</sup>-32/350

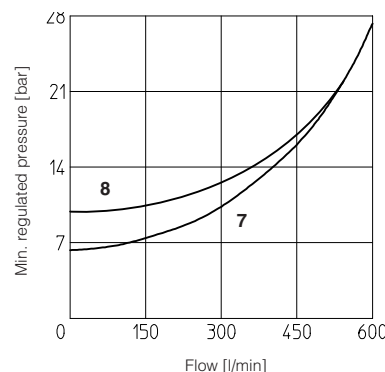
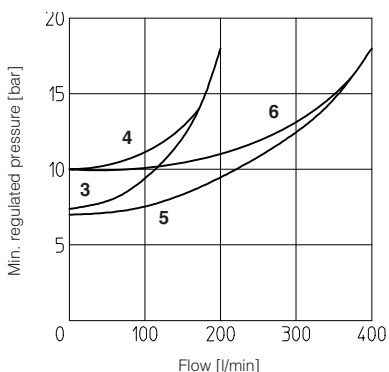

**7 HYDRAULIC OPTIONS**

**Option E**

External pilot option to be selected when the pilot pressure is supplied from a different line respect to the P main line.

With option E the internal connection between port P and X of the valve is plugged. The pilot pressure must be connected to the X port available on the valve's mounting surface or on main body (threaded pipe connection G 1/4").

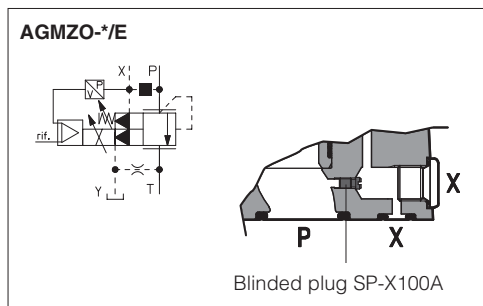

**Option Y**

The external drain is mandatory in case the main line T is subjected to pressure peaks or it is pressurized.

The Y drain port has a threaded connection G 1/4" available on the pilot stage body.

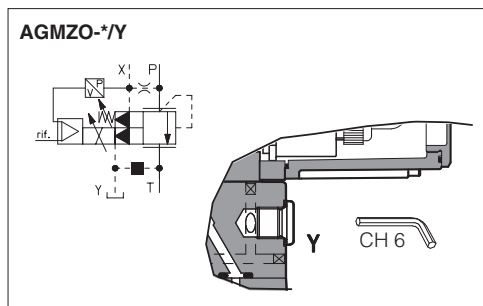

**8 MECHANICAL PRESSURE LIMITER**

The AGMZO are provided with mechanical pressure limiter acting as protection against overpressure. For safety reasons the factory setting of the mechanical pressure limiter is fully unloaded (min pressure).

At the first commissioning it must be set at a value lightly higher than the max pressure regulated with the proportional control.

For the pressure setting of the mechanical pressure limiter, proceed according to following steps:

- apply the max reference input signal to the valve's driver. The system pressure will not increase until the mechanical pressure limiter remains unloaded.
- turn clockwise the adjustment screw ① until the system pressure will increase up to a stable value corresponding to the pressure setpoint at max reference input signal.
- turn clockwise the adjustment screw ① of additional 1 or 2 turns to ensure that the mechanical pressure limiter remains closed during the proportional valve working.

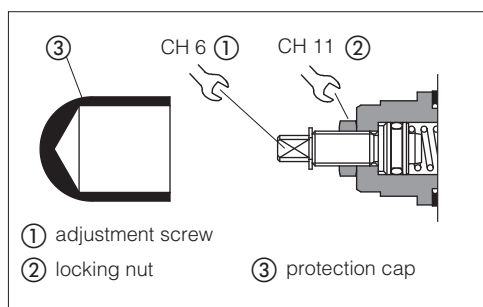

## 9 AIR BLEEDING

At the first valve commissioning the air eventually trapped inside the solenoid must be bled-off through the screw ① located at the rear side of the solenoid housing.  
The presence of air may cause pressure instability and vibrations.

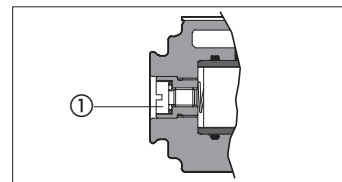

## 10 REMOTE PRESSURE UNLOADING

The **P** main line can be remotely unloaded by connecting the valve X port to a solenoid valve as shown in the below scheme (venting valve).  
This function can be used in emergency to unload the system pressure by-passing the proportional control.

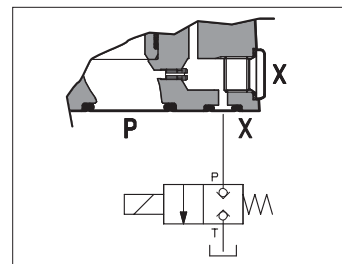

## 11 DYNAMIC RESPONSE - 4 pressure PIDs

The valve is provided with 4 PIDs configurations to match different hydraulic conditions. The required PID configuration can be selected before the valve commissioning, through Atos E-SW software via USB port. Only for **RES** the PID can be also selected in real time, through PLC via fieldbus.

PID	Dynamic response example diagrams at side
1	Fast - default (1)
2	Standard
3	Smooth
4	Open Loop

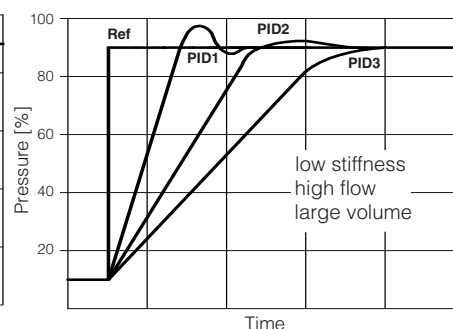
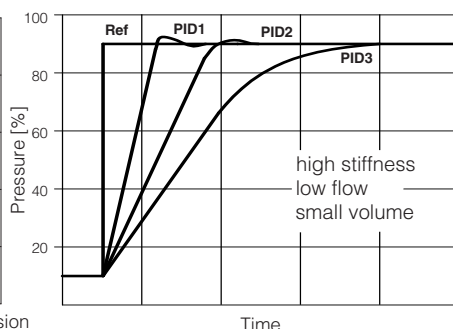

(1) interchangeable with previous TERS version

Above indications have to be considered as a general guideline, being affected by hydraulic circuit stiffness, working flow and dead volume. The valve's dynamics can be further optimized on the specific application, customizing PIDs parameters.

## 12 PRESSURE TRANSDUCER FAILURE

In case of pressure transducer failure, the valve's reaction can be configured through Atos E-SW software to:  
- cut off the current to solenoid, therefore the regulated pressure will be reduced to minimum value (default setting)  
- automatically switch the pressure control from closed loop (PID1,2,3) to open loop (PID4), to let the valve to temporarily operate with reduced regulation accuracy

## 13 ELECTRONIC OPTIONS

Standard driver execution provides on the 7 pin main connector:

**Power supply** - 24Vdc must be appropriately stabilized or rectified and filtered; a 2,5 A safety fuse is required in series to each driver power supply. Apply at least a 10000  $\mu$ F/40 V capacitance to single phase rectifiers or a 4700  $\mu$ F/40 V capacitance to three phase rectifiers

**Reference input signal** - analog differential input with 0÷+10 Vdc nominal range (pin D,E), proportional to desired valve pressure regulation

**Monitor output signal** - analog output signal proportional to the actual valve pressure regulation = 0÷+10 Vdc nominal range

**Note:** a minimum booting time of 500 ms has to be considered from the driver energizing with the 24 VDC power supply before the valve has been ready to operate. During this time the current to the valve coils is switched to zero..

### 13.1 Option /I

It provides 4 ÷ 20 mA current reference and monitor signals, instead of the standard  $\pm$ 10 V.

Input signal can be reconfigured via software selecting between voltage and current, within a maximum range of  $\pm$ 10 V or  $\pm$ 20 mA.

It is normally used in case of long distance between the machine control unit and the valve or where the reference signal can be affected by electrical noise; the valve functioning is disabled in case of reference signal cable breakage.

### 13.2 Option /Q

It provides the possibility to enable or disable the valve functioning without cutting the power supply (the valve functioning is disabled but the driver current output stage is still active). To enable the driver supply a 24 VDC on the enable input signal.

### 13.3 Option /Z

It provides, on the 12 pin main connector, the following additional features:

#### Enable Input Signal

To enable the driver, supply 24 VDC on pin 3 referred to pin 2: when the Enable signal is set to zero the valve functioning is disabled (zero current to the solenoid) but the driver current output stage is still active.

#### Fault Output Signal

Fault output signal indicates fault conditions of the driver (solenoid short circuits/not connected, reference signal cable broken for 4÷20mA input, etc.). Fault presence corresponds to 0 VDC, normal working corresponds to 24 VDC (pin 11 referred to pin 2): Fault status is not affected by the Enable input signal.

#### Power supply for driver's logics and communication

Separated power supply for the solenoid (pin 1, 2) and for the digital electronic circuits (pin 9, 10).

Cutting solenoid power supply allows to interrupt the valve functioning but keeping energized the digital electronics thus avoiding fault conditions of the machine fieldbus controller.

### 13.4 Possible combined options: /IQ, /IZ

## 14 ELECTRONIC CONNECTIONS

### 14.1 Main connector signals - 7 pin - standard and /Q option - AGMZO-REB and AGMZO-RES (A1)

PIN	Standard	/Q	TECHNICAL SPECIFICATIONS	NOTES
A	V+		Power supply 24 Vdc	Input - power supply
B	V0		Power supply 0 Vdc	Gnd - power supply
C	AGND		Analog ground	Gnd - analog signal
		ENABLE	Enable (24 Vdc) or disable (0 Vdc) the driver, referred to V0	Input - on/off signal
D	P_INPUT+		Pressure reference input signal: $\pm 10$ Vdc / $\pm 20$ mA maximum range Defaults are 0 $\div$ 10 Vdc for standard and 4 $\div$ 20 mA for /I option	Input - analog signal <b>Software selectable</b>
E	INPUT-		Negative reference input signal for P_INPUT+	Input - analog signal
F	P_MONITOR referred to: AGND	V0	Pressure monitor output signal: 0 $\div$ 10 Vdc / 0 $\div$ 20 mA maximum range, referred to VL0 Defaults are 0 $\div$ 10 Vdc for standard and 4 $\div$ 20 mA for /I option	Output - analog signal <b>Software selectable</b>
G	EARTH		Internally connected to driver housing	

### 14.2 Main connector signals - 12 pin - /Z option - AGMZO-REB and AGMZO-RES (A2)

PIN	/Z	TECHNICAL SPECIFICATIONS	NOTES
1	V+	Power supply 24 Vdc	Input - power supply
2	V0	Power supply 0 Vdc	Gnd - power supply
3	ENABLE	Enable (24 Vdc) or disable (0 Vdc) the driver, referred to V0	Input - on/off signal
4	P_INPUT+	Pressure reference input signal: $\pm 10$ Vdc / $\pm 20$ mA maximum range Defaults are 0 $\div$ 10 Vdc for standard and 4 $\div$ 20 mA for /I option	Input - analog signal <b>Software selectable</b>
5	INPUT-	Negative reference input signal for P_INPUT+	Input - analog signal
6	P_MONITOR	Pressure monitor output signal: 0 $\div$ 10 Vdc / 0 $\div$ 20 mA maximum range, referred to VL0 Defaults are 0 $\div$ 10 Vdc for standard and 4 $\div$ 20 mA for /I option	Output - analog signal <b>Software selectable</b>
7	NC	Do not connect	
8	NC	Do not connect	
9	VL+	Power supply 24 Vdc for driver's logic and communication	Input - power supply
10	VL0	Power supply 0 Vdc for driver's logic and communication	Gnd - power supply
11	FAULT	Fault (0 Vdc) or normal working (24 Vdc), referred to V0	Output - on/off signal
PE	EARTH	Internally connected to driver housing	

### 14.3 Communication connectors - AGMZO-REB (B) and AGMZO-RES (B) (C)

(B) USB connector - M12 - 5 pin always present		
PIN	SIGNAL	TECHNICAL SPECIFICATION (1)
1	+5V_USB	Power supply
2	ID	Identification
3	GND_USB	Signal zero data line
4	D-	Data line -
5	D+	Data line +

(C1) BC fieldbus execution, connector - M12 - 5 pin (2)		
PIN	SIGNAL	TECHNICAL SPECIFICATION (1)
1	CAN_SHLD	Shield
2	NC	do not connect
3	CAN_GND	Signal zero data line
4	CAN_H	Bus line (high)
5	CAN_L	Bus line (low)

(C2) BP fieldbus execution, connector - M12 - 5 pin (2)		
PIN	SIGNAL	TECHNICAL SPECIFICATION (1)
1	+5V	Termination supply signal
2	LINE-A	Bus line (high)
3	DGND	Data line and termination signal zero
4	LINE-B	Bus line (low)
5	SHIELD	

(C3) (C4) EH fieldbus execution, connector - M12 - 4 pin (2)		
PIN	SIGNAL	TECHNICAL SPECIFICATION (1)
1	TX+	Transmitter
2	RX+	Receiver
3	TX-	Transmitter
4	RX-	Receiver
Housing	SHIELD	

Notes: (1) shield connection on connector's housing is recommended (2) only for RES execution

### 14.4 Solenoid connection - only for AGMZO-R

PIN	SIGNAL	TECHNICAL SPECIFICATION	Connector code 666
1		Power supply	
2		Power supply	
3		GNG	

### 14.5 Pressure transducer connection - only for AGMZO-R

PIN	SIGNAL	TECHNICAL SPECIFICATION	Connector code ZBE-08
1	V+	Power supply	
2	NC	Not connected	
3	Vout	output signal 4 $\div$ 20 mA	
4	NC	Not connected	
5	NC	Not connected	

14.6 Connections layout - only for REB and RES

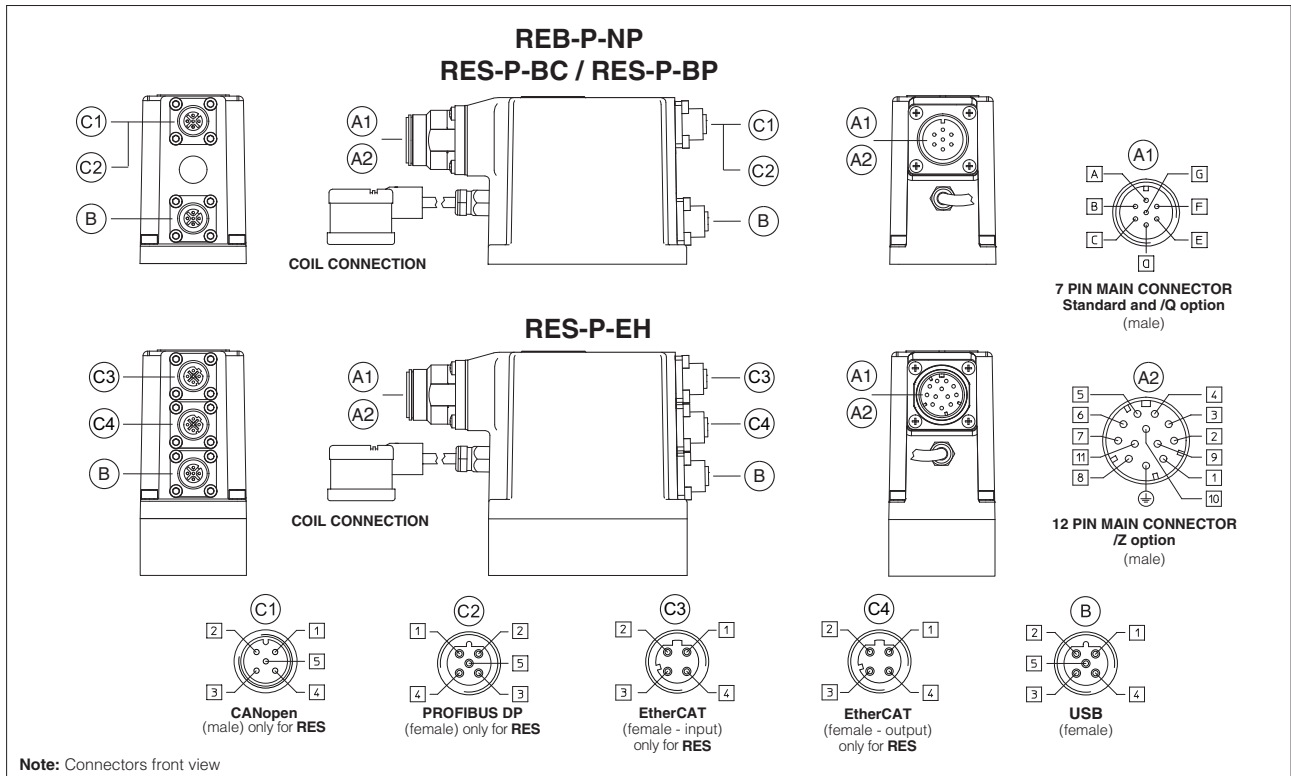

15 CONNECTORS

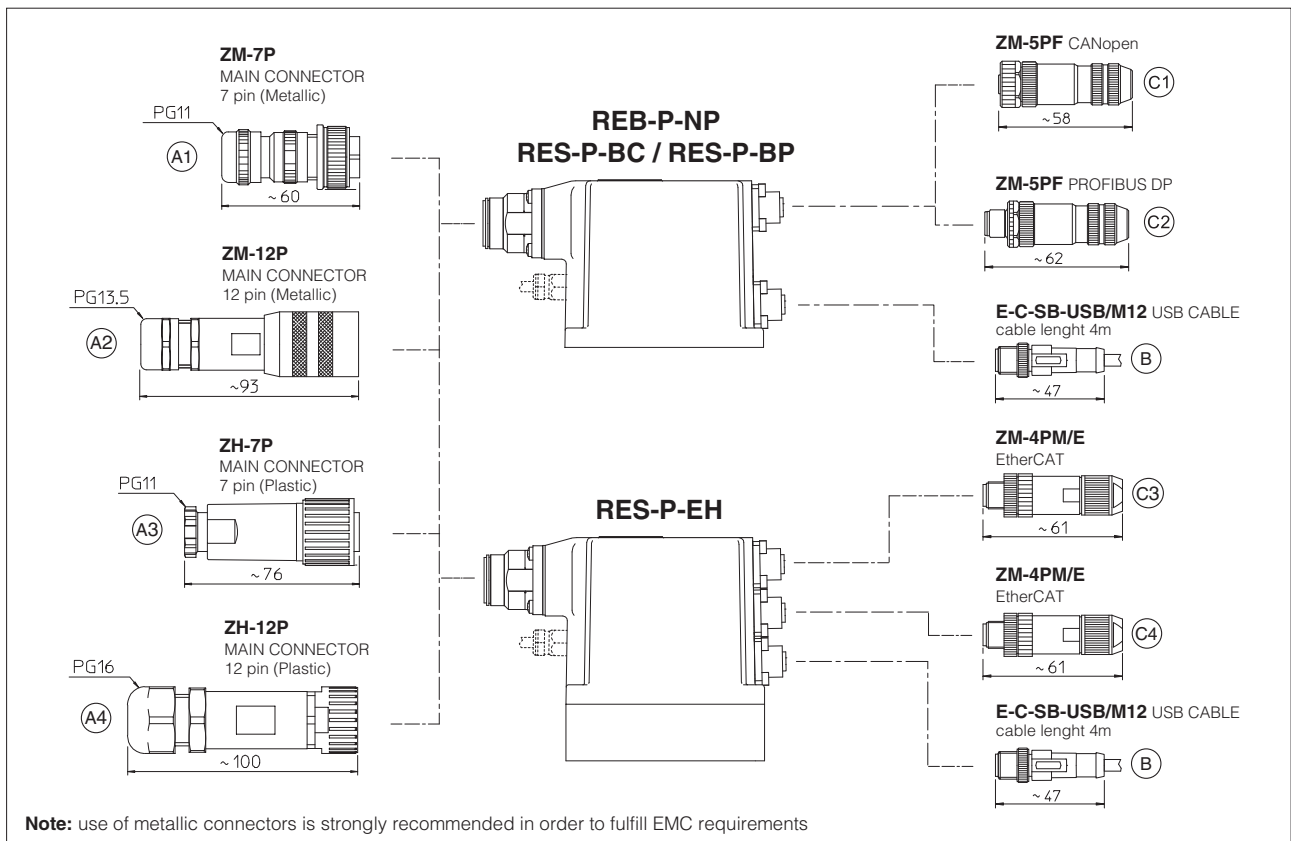

16 MODEL CODES OF MAIN CONNECTORS AND COMMUNICATION CONNECTORS - to be ordered separately

VALVE VERSION	R (1)		REB RES	REB/Z RES/Z	BC - CANopen	BP - PROFIBUS DP	EH - EtherCAT
	Power supply	Pressure transducer					
CONNECTOR CODE	666	ZBE-08	ZM-7P (A1)	ZM-12P (A2)	ZM-5PF (C1)	ZM-5PF/BP (C2)	ZM-4PM/E (C3)
			ZH-7P (A3)	ZH-12P (A4)			ZM-4PME (C4)
PROTECTION DEGREE	IP65		IP67				
DATA SHEET	K500		GS205, K500				

(1) Connectors supplied with the valve

only for RES

**17 PROGRAMMING TOOLS** - see tech table **GS500**

Valve's functional parameters and configurations, can be easily set and optimized using Atos E-SW programming software connected via USB port to the digital driver. For fieldbus versions, the software permits valve's parameterization through USB port also if the driver is connected to the central machine unit via fieldbus.

The software is available in different versions according to the driver's options:

**E-SW-BASIC** support: NP (USB) PS (Serial) IR (Infrared)

**E-SW-FIELDBUS** support: BC (CANopen) BP (PROFIBUS DP) EH (EtherCAT)  
EW (POWERLINK)

**E-SW-\*/PQ** support: valves with SP, SF, SL alternated control (e.g. E-SW-BASIC/PQ)

**WARNING: drivers USB port is not isolated!**

The use of isolator adapter is highly recommended for PC protection (see table **GS500**)

**USB connection**

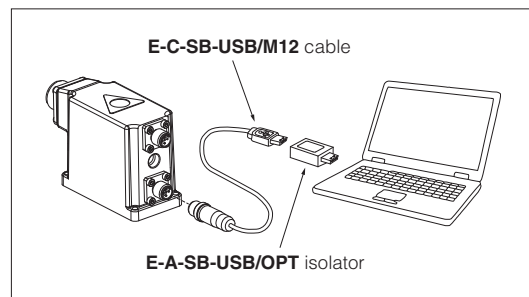

**18 INSTALLATION DIMENSIONS of AGMZO [mm]**

**SIZE 10**

**ISO 6264: 2007**

**Mounting surface: 6264-06-09-1-97 (see table P005)**

Fastening bolts: 4 socket head screws

M12x35 class 12.9

Tightening torque = 125 Nm

Seals: 2 OR 123, 1 OR 109/70

Ports P, T: Ø = 14 mm

Port X: Ø = 3,2 mm

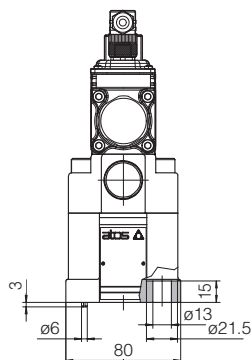

**AGMZO-R-P-10**

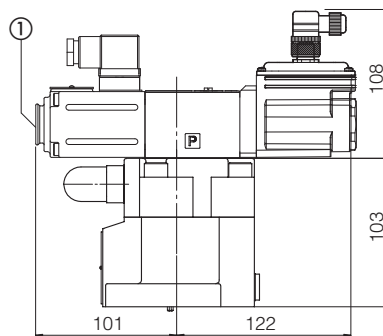

Mass: 5,7 Kg

**AGMZO-REB-P-NP-10  
AGMZO-RES-P-BC-10  
AGMZO-RES-P-BP-10**

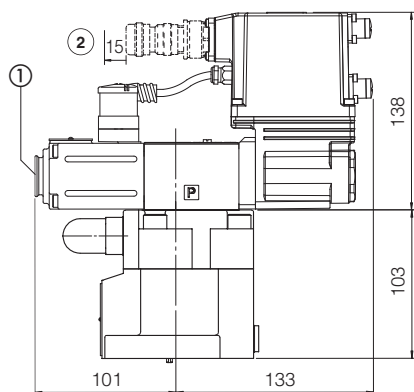

Mass: 6,2 Kg

**AGMZO-RES-P-EH-10**

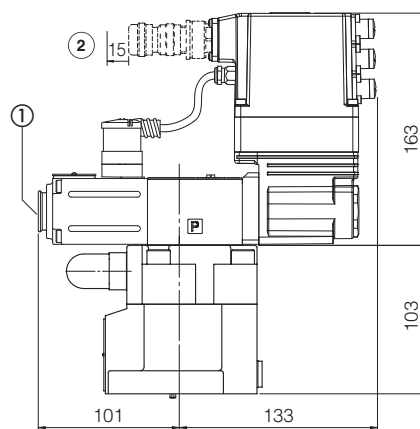

Mass: 6,3 Kg

- ① = Screw for air bleeding: at the first valve commissioning the air eventually trapped inside the solenoid must be bled-off through the screw ①
- ② = Space to remove the 7 or 12 pin main connector. For main and communication connectors see section **15**, **16**

## SIZE 20

ISO 6264: 2007

Mounting surface: 6264-08-13-1-97  
(see table P005)

Fastening bolts: 4 socket head screws  
M16x50 class 12.9  
Tightening torque = 300 Nm  
Seals: 2 OR 4112, 1 OR 109/70  
Ports P, T:  $\varnothing = 24$  mm  
Port X:  $\varnothing = 3,2$  mm

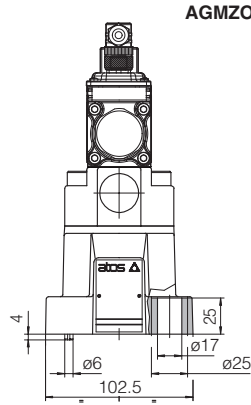

AGMZO-R-P-20

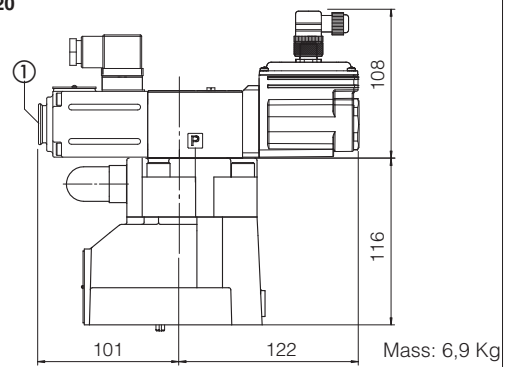

AGMZO-REB-P-NP-20  
AGMZO-RES-P-BC-20  
AGMZO-RES-P-BP-20

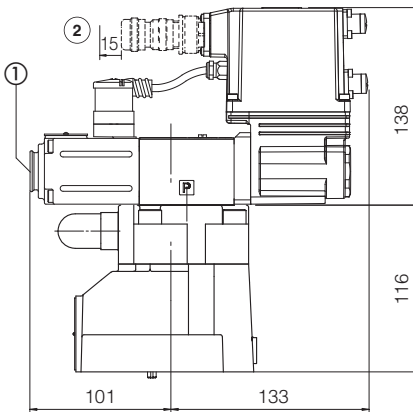

Mass: 7,4 Kg

AGMZO-RES-P-EH-20

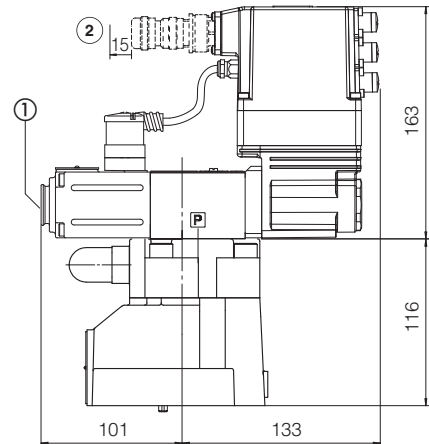

Mass: 7,5 Kg

## SIZE 32

ISO 6264: 2007

Mounting surface: 6264-10-17-1-97  
(see table P005)

(with M20 fixing holes instead of standard M18)

Fastening bolts: 4 socket head screws  
M20x60 class 12.9  
Tightening torque = 600 Nm  
Seals: 2 OR 4131, 1 OR 109/70  
Ports P, T:  $\varnothing = 28$  mm  
Port X:  $\varnothing = 3,2$  mm

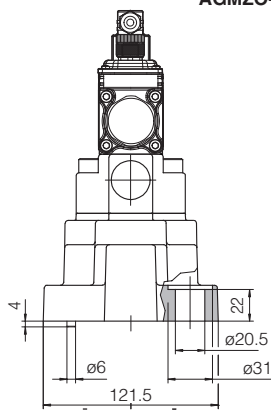

AGMZO-R-P-32

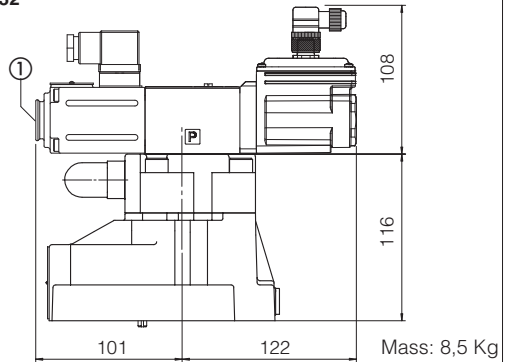

AGMZO-REB-P-NP-32  
AGMZO-RES-P-BC-32  
AGMZO-RES-P-BP-32

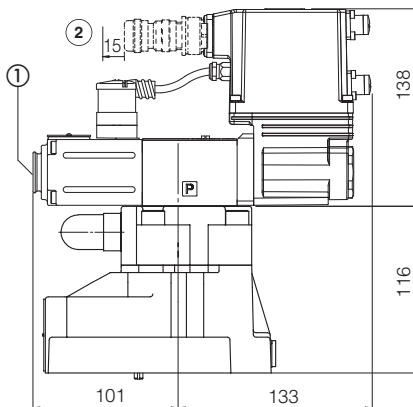

Mass: 9,0 Kg

AGMZO-RES-P-EH-32

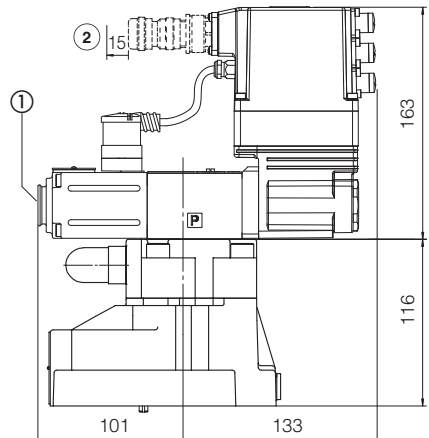

Mass: 9,1 Kg

- ① = Screw for air bleeding: at the first valve commissioning the air eventually trapped inside the solenoid must be bled-off through the screw ①  
② = Space to remove the 7 or 12 pin main connector. For main and communication connectors see section 15, 16